

Palletizing Equipment

Introducing the newest member of
von GAL's Palletizer Line

The **VAL-U-PAL** combines the basic flexibility of a traditional robotic palletizer with the simplicity and maintainability of a traditional palletizer (*industry standard components such as PLCs are used throughout*). All of this is accomplished at the industries' lowest cost for a fully automated palletizer including infeed conveying, pallet dispensing and handling, and slip sheet handling. The total cost of a **VAL-U-PAL** system, in most instances, will be less than the cost of a basic robot arm.

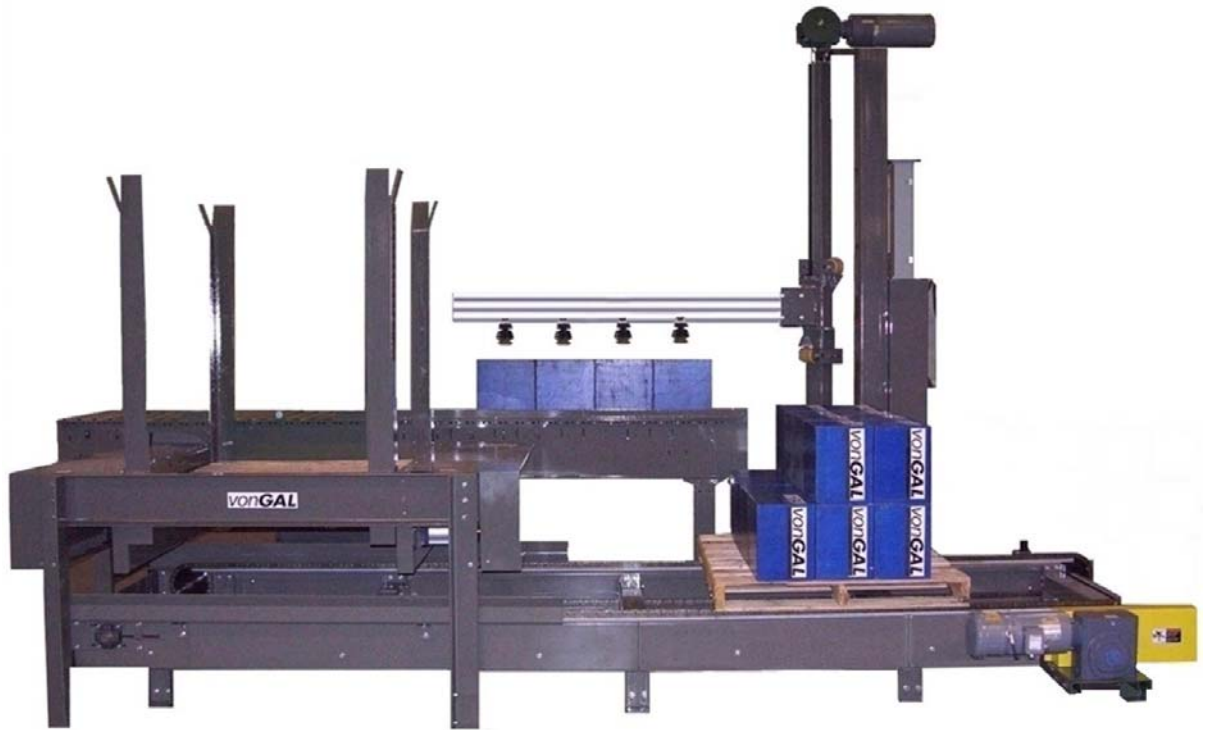

 **vongAL**

Palletizers · Pallet Handling · Integration
www.vongal.com

800-542-6570
334-261-2700

“A TRADITION OF QUALITY SINCE 1957”

VAL-U-PAL

Palletizing Equipment

Newest Member of *von GAL's* Palletizer Line **VAL-U-PAL**

GENERAL SPECIFICATIONS

- Operation Completely automatic, no operator required
- Case Rate CPM 10-16 / Min Column Stack / Simple cross tie
CPM 8-10 / Min Interlocked pattern
- Cycle Rate Up to 4 cycles per minute
- Electrical System 230 / 460 / 3 phase / 60 cycle
6 HP motor
- Maximum Lift 250 lbs.
- Case Weight 30 lbs. With vacuum pickup
- Pallets 4840 GMA or CHEP

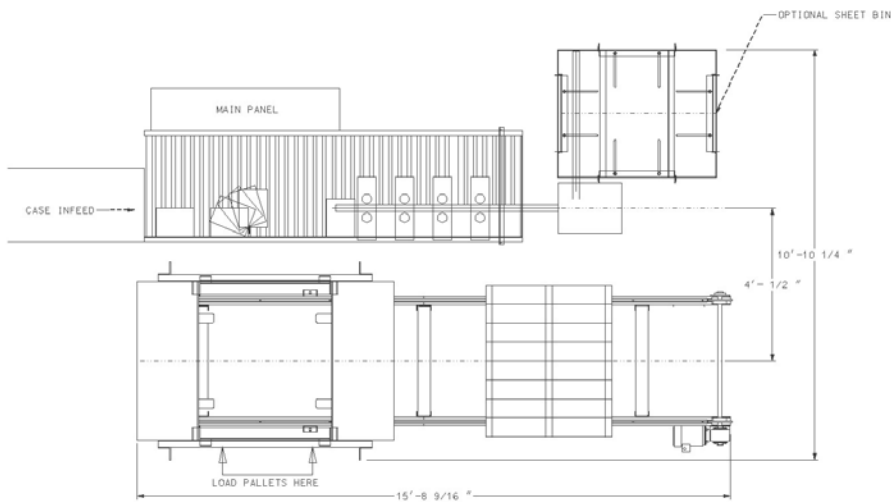

OPTIONS

- PLC Upgrades
- Sheet Dispenser
- Unitizer
- Additional Features Available

